

Vertical Case

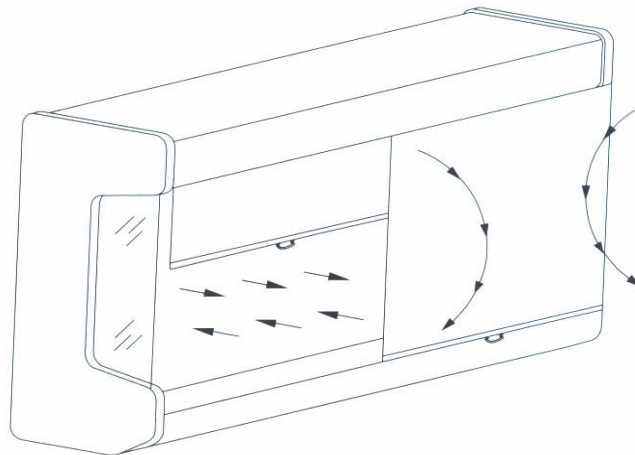

Island Case



**Combination
Island Case**

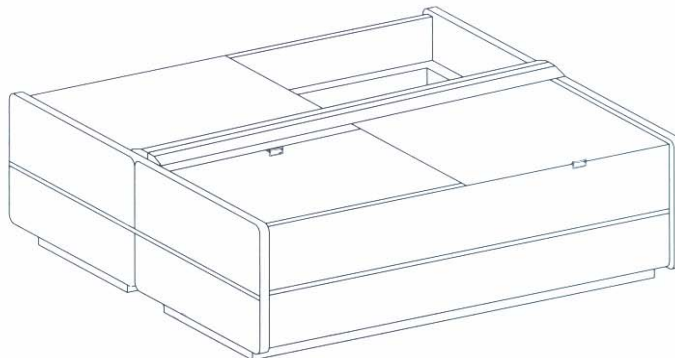

NIGHT BLIND CURTAINS

Dixell (Asia) Co., Ltd.

207/71-72 Soi Pattanakarn 61, Pattanakarn Road
Praves, Bangkok 10250
Tel. +66 2 321 3078
Fax. +66 2 320 2520

email : dixell@dixellasia.com

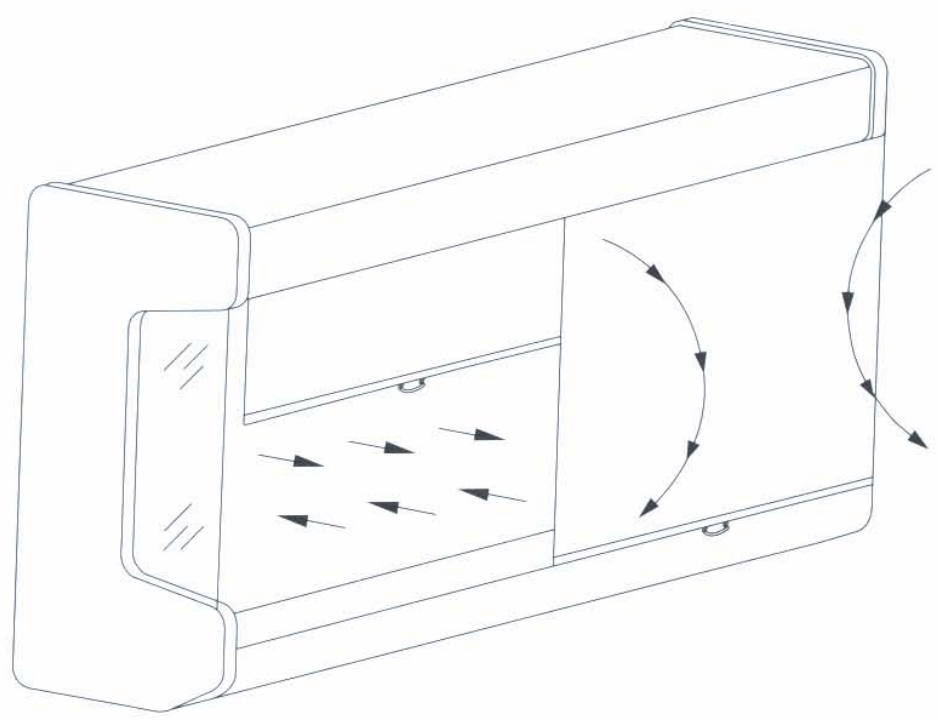
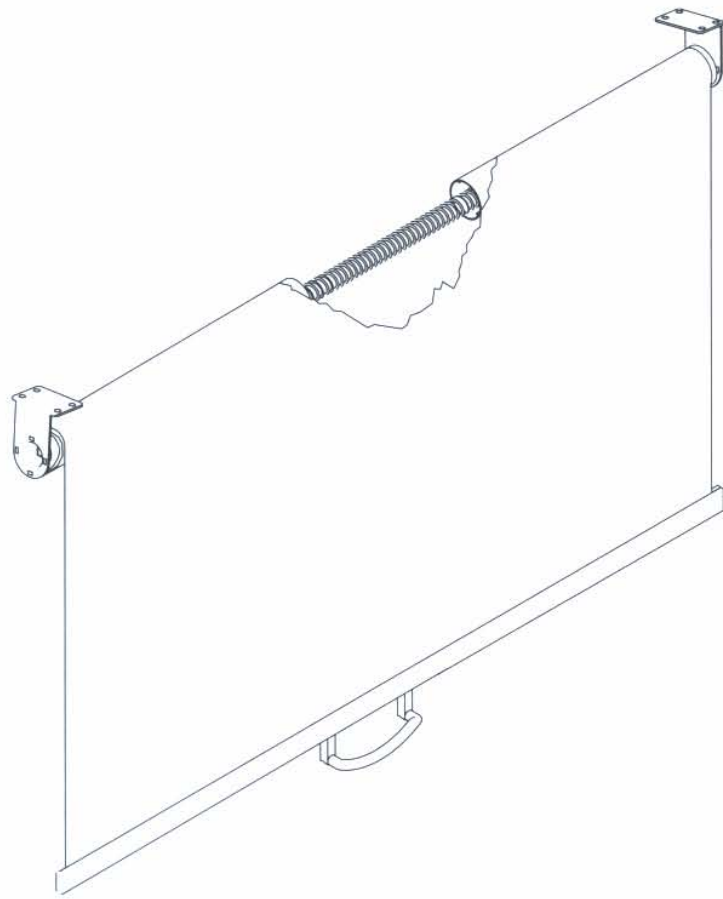

Sketch map of night blind for vertical cases

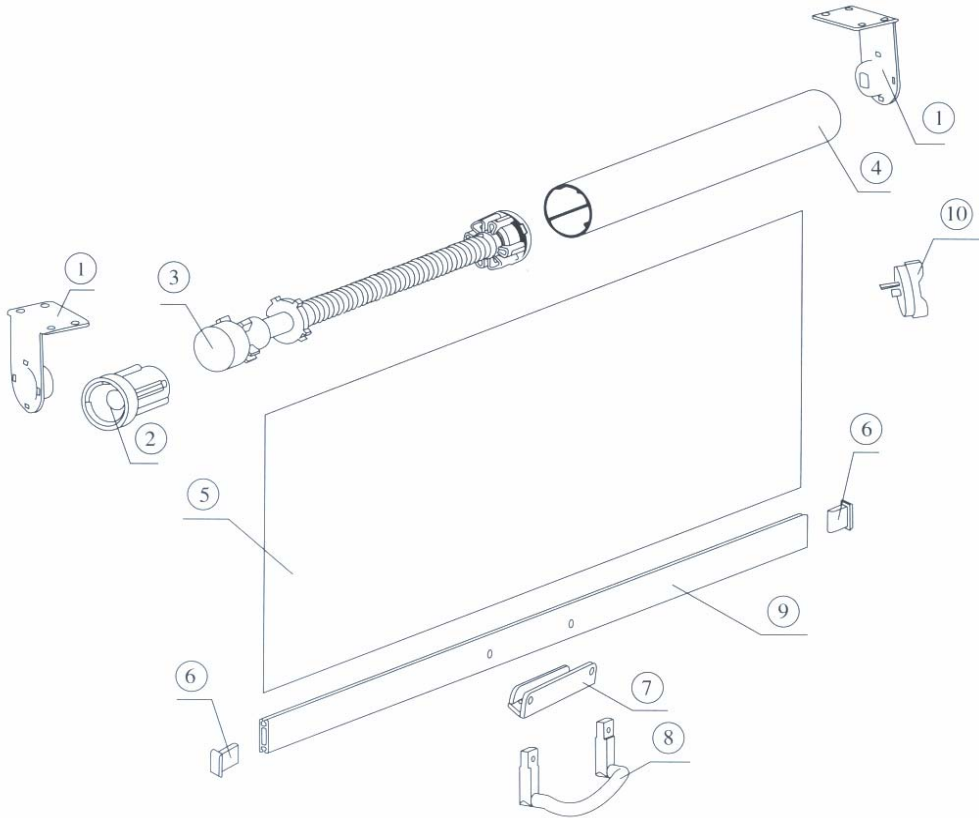

Exploded view of night blind for vertical cases

1	BRACKET
2	END PIECE
3	SPRING
4	ROLLER TUBE
5	MATERIAL (SILVER CLOTH)
6	BOTTOM RAIL END PIECE
7	BLIND HOOK
8	HANDLE
9	ALUMINIUM BOTTOM RAIL
10	REGULATE

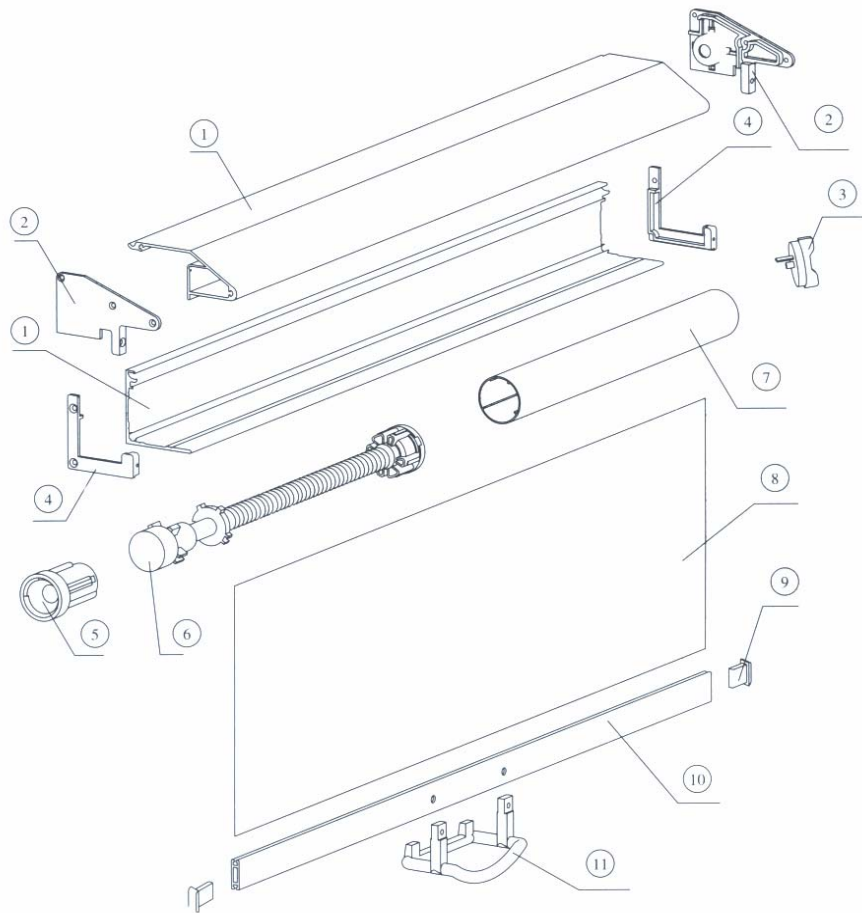

Exploded view of the first type of night blind with aluminum cassette

1	ALUMINIUM CASSETTE
2	COVER PLATE
3	REGULATE
4	BRACKET
5	END PIECE
6	SPRING
7	ROLLER TUBE
8	MATERIAL (SILVERCLOTH)
9	ALUMNIUM BOTTOMRAIL
10	BOTTOMRAIL END PIECE
11	HANDLE

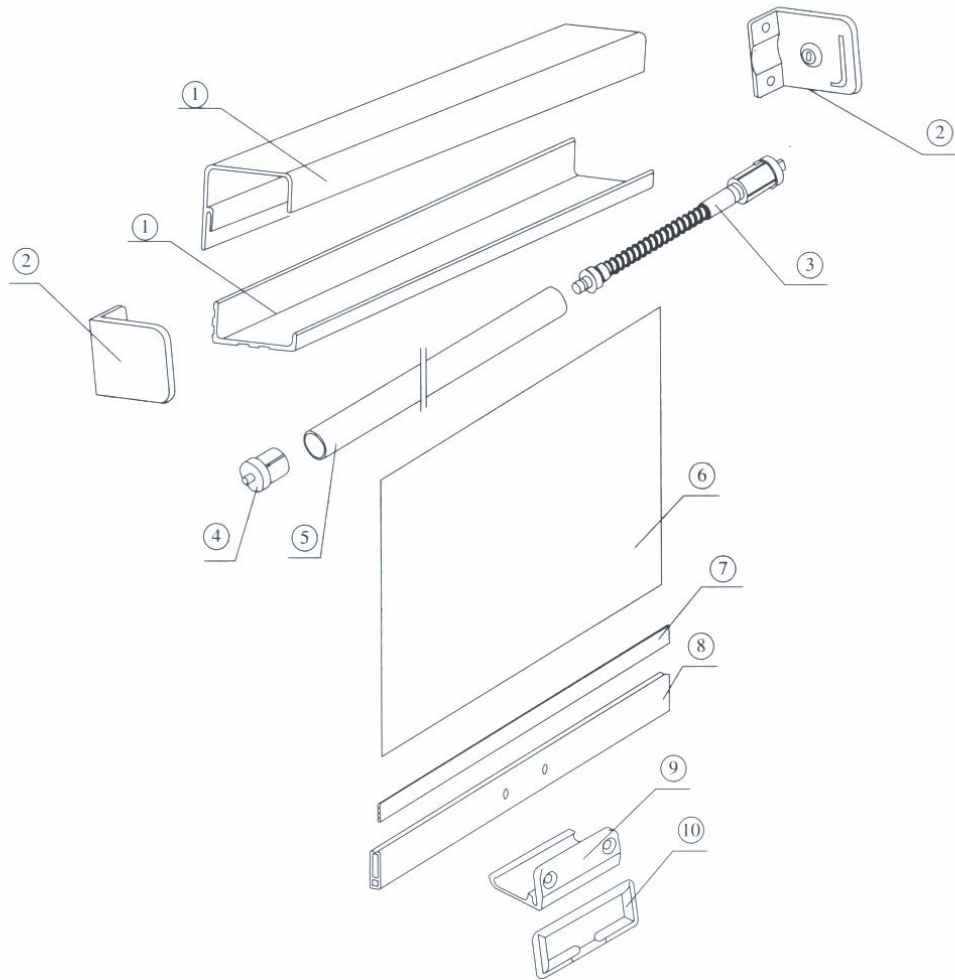

Exploded view of the Second type of night blind with aluminum cassette

1	ALUMINIUM CASSETTE
2	COVER PLATE
3	SPRING
4	END PIECE
5	ROLLER TUBE
6	MATERIAL (ALMINIUM COATED)
7	HEART TWIG
8	BOTTOM RAIL
9	BLIND HOOK
10	HANDLE

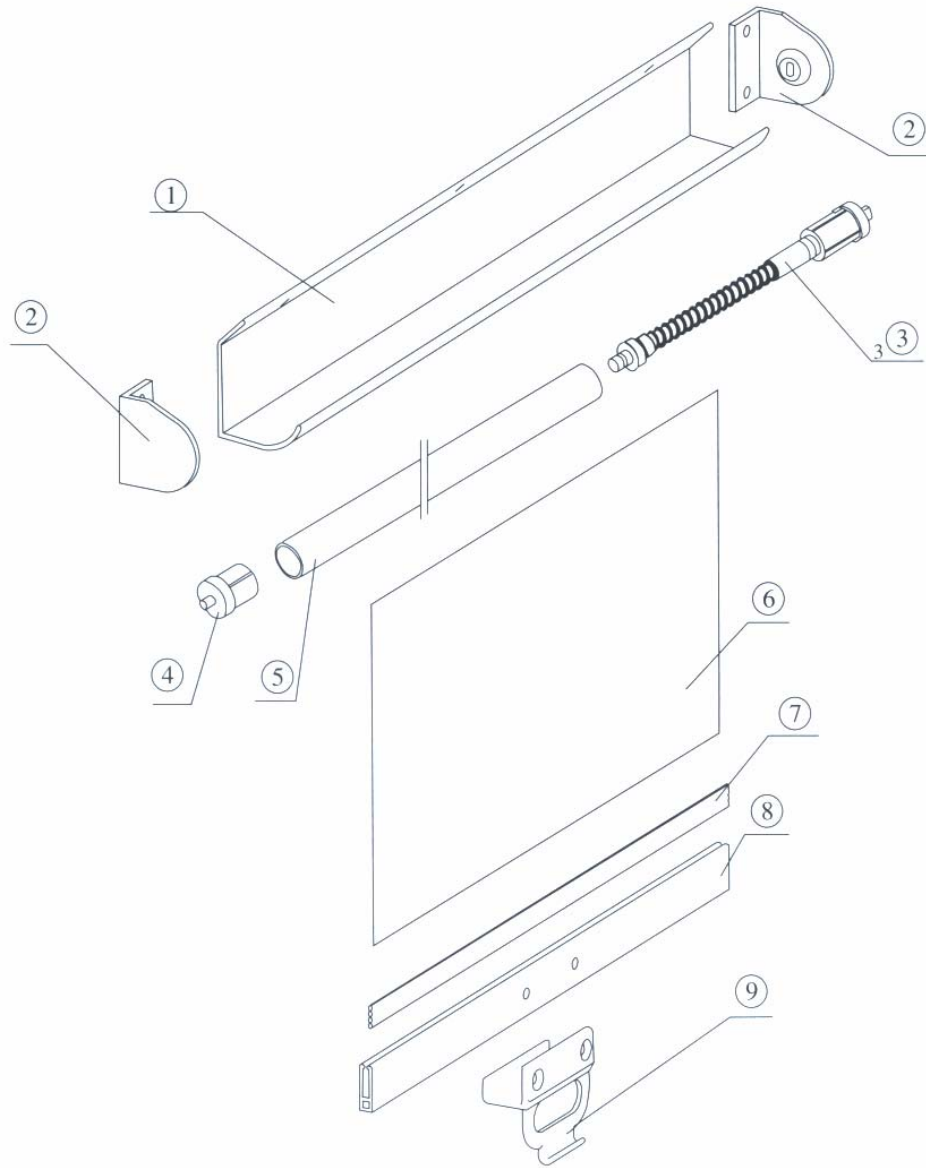

Exploded view of night blind for vertical cases

1	ABS CASSETTE
2	COVER PLATE
3	SPRING
4	END PIECE
5	ROLLER TUBE
6	MATERIAL (ALMINIUM COATED)
7	HEART TWIG
8	BOTTOMRIAL
9	HANDLE

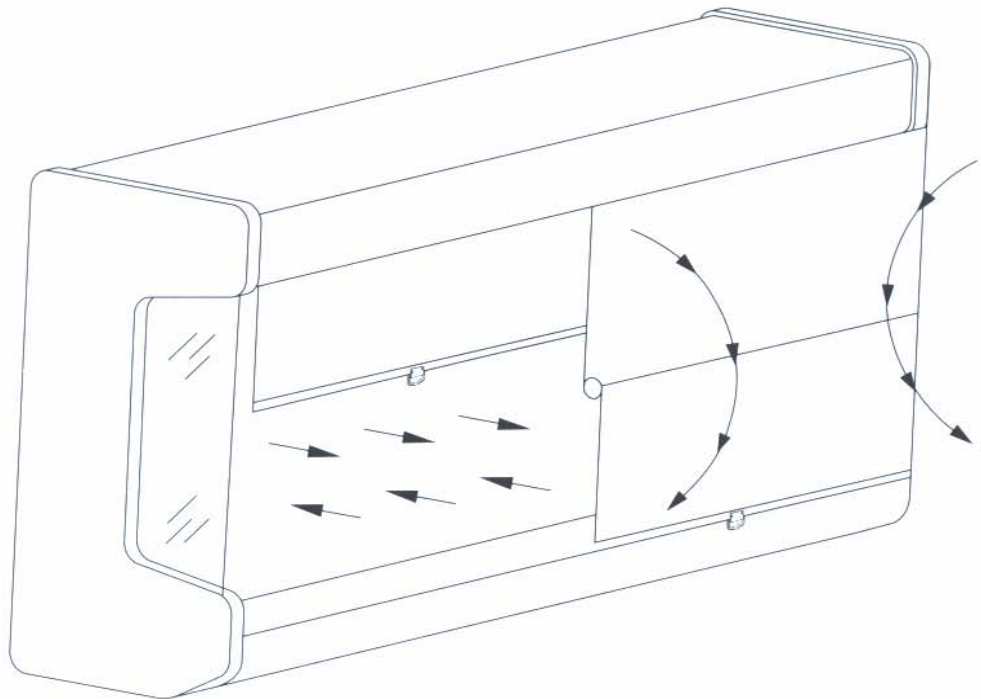
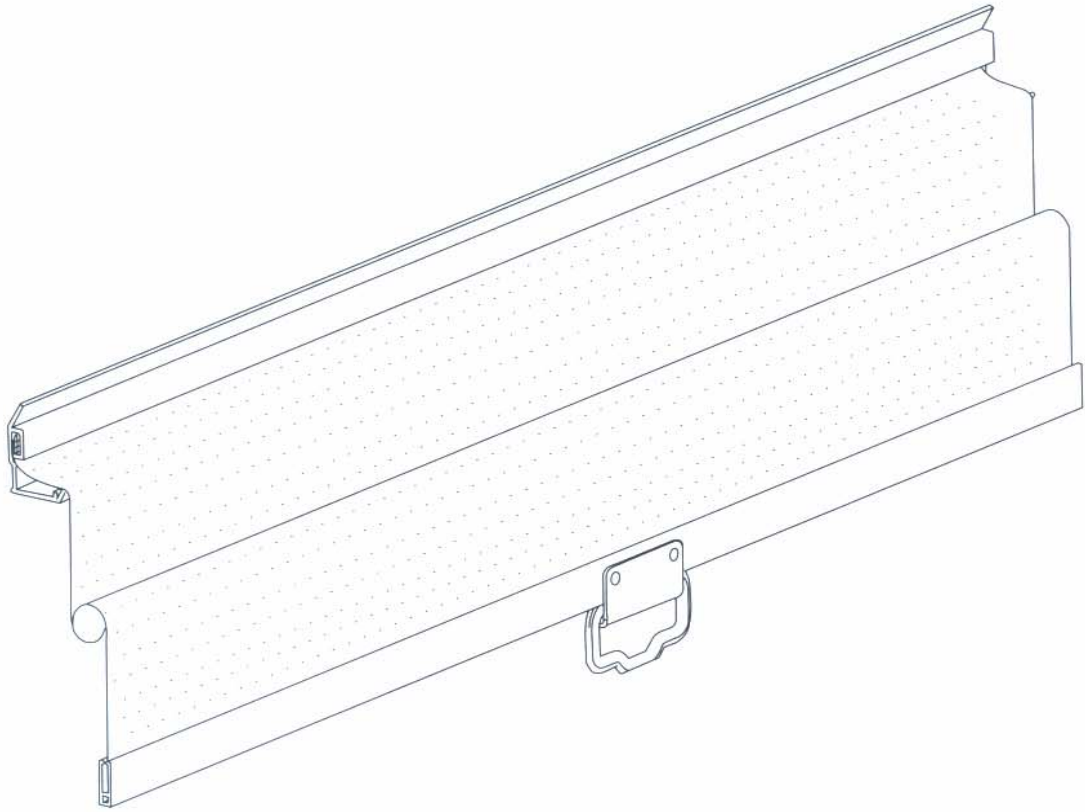

Sketch map of night blind reeled by itself